

Small-scale wood-fired CHP units for buildings and building blocks

GUIDE 2016

CHP units use fuel to co-generate heat and power in one process. This guide is about **small** and **micro CHP units** that burn wood pellets or wood chips.

Investing on a wood-fired CHP unit to generate energy for a building or a building block is an option to be considered when

- there is no district heating available
- target is to minimize the CO₂-eqv emissions of energy use
- project aims to be as independent from the grid as possible
- wood chips or pellets are available within reasonable costs.

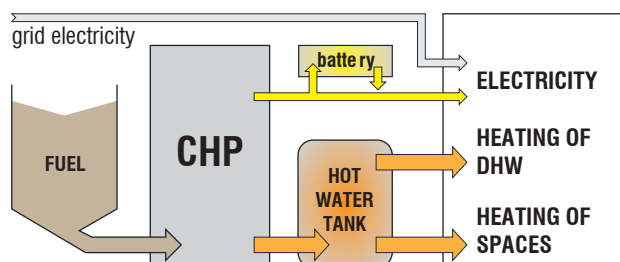

The ratio between electricity and heat in co-generation depends on the technology. In all solutions available, the amount of heating energy always exceeds the amount of electricity generated.

Pros and cons

- + electricity comes from renewable source, and the output is not dependant on location, season or weather conditions (as in the case of wind turbines or photovoltaic panels)
- + wood chips and wood pellets are domestic fuels
- + the CO₂-eqv emissions of wood burning are considered extremely low in carbon footprint calculation
- + maintenance costs are reasonable
- investment costs are high
- chp unit and fuel storage need a lot of space
- there are no long-term experiences of performance and maintenance yet
- the excess electricity is typically fed into the grid, and the price paid for this electricity is very low

CHP	<i>combined heat and power</i> , co-generation of electricity and heating energy. CHP technologies are developed for various kinds of fuels, for example gas, biomass or wood.
small-CHP	CHP unit for small residential area, building block or large building; electric power generation 10 – 1000 kW _e .
micro-CHP	a small CHP unit for a single building; electric power < 10 kW _e .
stirling	(stirling engine) engine type utilizing gas expansion; can be used to generate electricity from heat.
gasification	solid fuel (for example wood chip) is transformed into gas in high temperature; gas can be used as fuel.
farmivirta	name for a contract arrangement with Oulun Energia; a real estate can sell renewable electricity from its site to its partner over the grid.
i-m³	volume unit for wood, cubic meter including wood and air.
battery	battery pack is located in it's own well ventilated airtight compartment according to manufacturer's instructions

Small CHP

electric power output 10 – 10000 kW_e

Small CHP units can be used to generate energy for block of buildings, small residential area or a single large building.

Small CHP unit is situated as any wood-fired heating utility. The fuel silo has to be refilled and the ash storage emptied regularly. Issues to be considered when choosing a site for a mini CHP unit:

- route for vehicles transporting wood chips or wood pellets; the safety of residents
- safe operation of the refill hatch in silo in all seasons and conditions
- fire safety (the distance from adjacent buildings, fire compartments)
- low-frequency noise caused by a CHP unit
- maintenance and the possibility to replace parts and components of the unit.

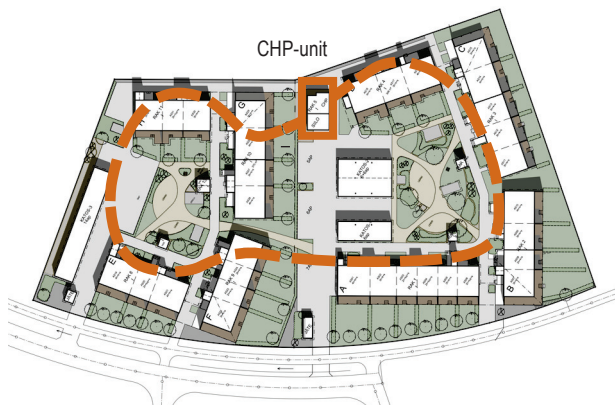

It is advantageous to situate CHP unit as part of the building block so that the heat losses are minimized.

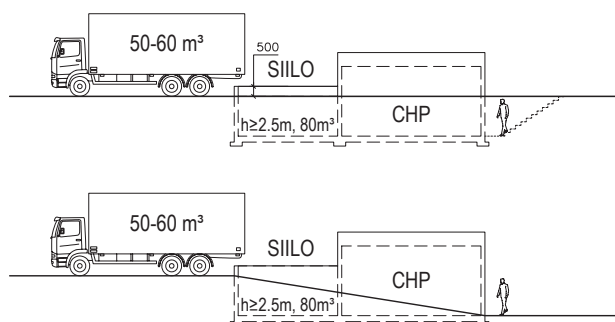

When considering the location of a fuel silo, it is necessary to take the shapes of the ground into consideration. The height difference may enable easy refill and an access to the pellet burner room.

Fire safety

Requirements for fire compartments and interior surface materials are specified in the Finnish Building Code part E9 – Fire Safety of Boiler Rooms and Solid Fuel Storages. It is difficult to make the refill hatch in silo to meet the requirements for fire partition structure. The required minimum distance to adjacent buildings needs to met also when the refill hatch is open.

The consultation with the fire inspection officer in the early stage of planning process is highly recommended if there is any uncertainty in the application of fire code regulation.

The fire classes for building parts forming fire compartments

DISTANCE < 8 m	P1	P2	P3
room for CHP unit (as part of building)			
<30 kW in ground floor or upper floors	EI 60	EI 30	EI 30
<30 kW in the basement	EI 60*1	EI 60*1	EI 30*1
≥ 30 kW	EI 60*1	EI 60*1	EI 60*1
SILO (as part of building)			
in the ground floor or upper floors	EI 120	EI 30	EI 30
in the basement	EI 120*	EI 60*	EI 30*
DISTANCE 8 m or more			
separate building, partition wall between boiler room and silo (no requirements for exterior walls)			
	P1	P2	P3
mostly above the ground level	EI 120	EI 30	— ²
mostly under the ground level	EI 120*	EI 60*	— ²

* minimum requirement: class A2-s1, 0d materials (inflammable)

¹ also exterior walls in class A2-s1, 0d

² spreading of dust has to be prevented

(silo in the basement) notice that it is difficult to make a fire classified silo refill hatch to close tight

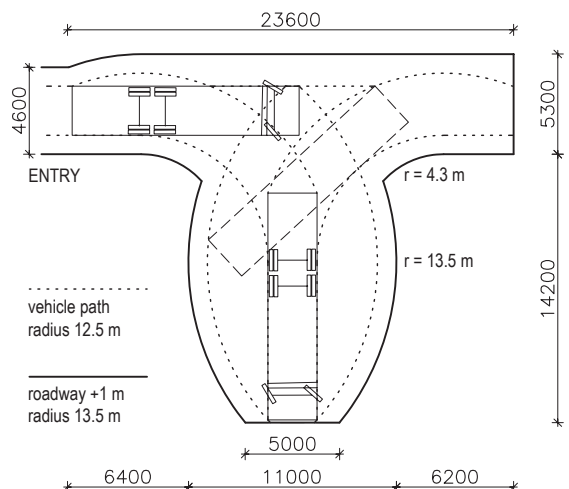

In the Oulu region, wood chips are transported in a dump trailer truck. The image above presents the dimensions of a turning place for a 12-meter truck which is used in small scale delivery of wood chips.

Case Volter Oy: A small CHP gasification unit

electric power	40 kW _e
heating power	100 kW _h
fuel consumption	4,5 i-m ³ (max.power/24h)

A CHP unit by the Finnish company Volter Oy uses gasification to co-generate heat and power from wood chips. The actual CHP device fits into a container.

Wood chips used as fuel have to be dried prior to use. In the Oulu region, the local energy company, Oulun Energia, is a supplier of dried wood chips. The gasification technology minimizes small particle emissions that are a major problem in wood burning processes. A standard-sized small chimney is enough for the CHP unit. The smoke does not cause any problems for the residents of the adjacent buildings.

In the Kempele eco block, a small CHP unit by Volter Oy and a wind turbine generate all the electricity and heating for a block of ten detached houses. The Kempele eco block is operated off-grid. All energy is renewable.

A residential block of eight row houses and a small CHP unit was completed in Kivikkokangas, Oulu in 2015. The small CHP unit by Volter provides the residents with all heating energy and the electricity for building equipment (ventilation, pumps, outdoor lighting). The tenant electricity comes from the grid.

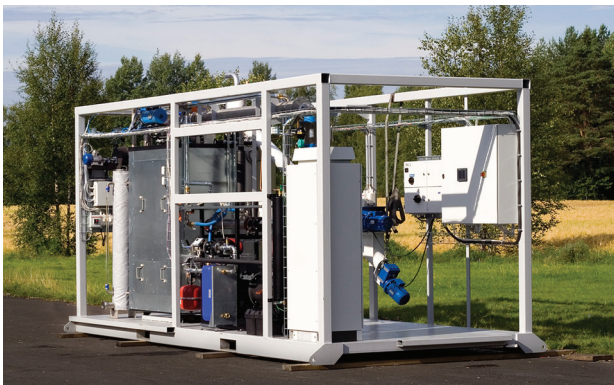

The CHP unit by Volter Oy fits in a container. The hot water storage tank is dimensioned case by case.

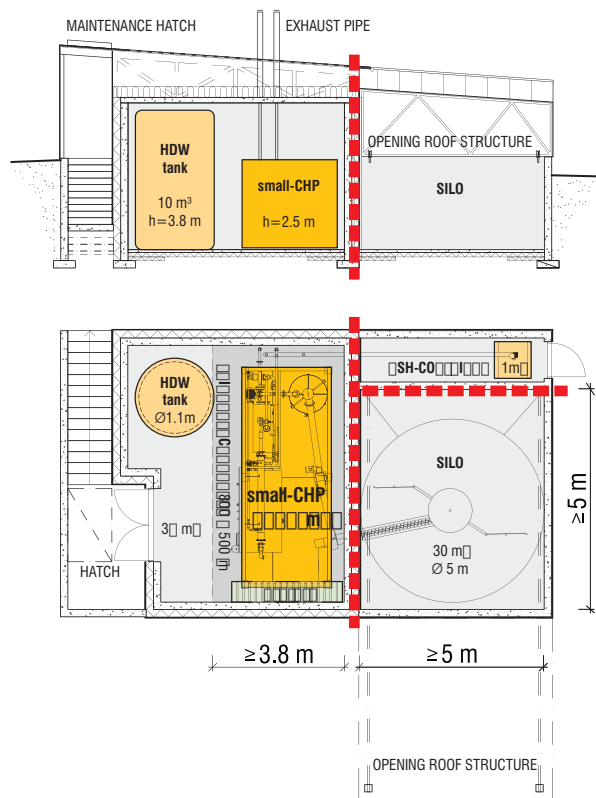

A mini chp-unit in a separate building.

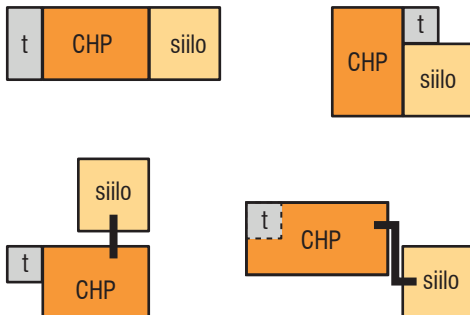

Optional spatial combinations. The space for a ash storage can be in a separate room or in the same room with the burner. A silo can also be a separate construction, and in that case there is an external conveyor to feed chips into the CHP boiler.

Examples of companies manufacturing small wood-fired CHP units in Nordic countries:

Volter Oy	www.volter.fi
Entimos Oy	www.entimos.fi
Energiprojekt	www.energiprojekt.com
Stirling.dk	www.stirling.dk

micro CHP

1-10 kW_e

Wood-fired micro CHP units are so far rare in Finland, and the long-term experiences are still missing.

Examples of companies manufacturing wood-fired micro CHP units:

Ökofen www.okofen-e.com

KWB www.kwb.at

Pellet storage in a boiler room

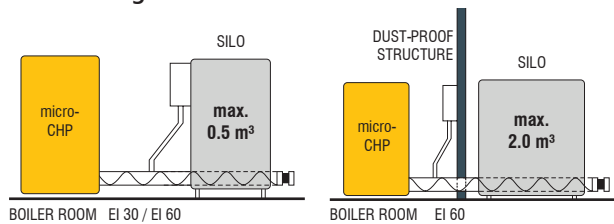

Pellematic smart_e 0.6 micro CHP unit.

Case Pellematic: A pellet-fired micro CHP Unit

heating power output	9 kW
electric power output	0,6 kW
small particle emissions	4 mg/Nm ³
CO emissions	31 mg/Nm ³
dimensions	1175 x 1150 x 1958 mm
price (average 2014)	approx. 24 t€

Pellematic smart_e 0.6 is one example of a pellet-fired micro CHP unit that can be used in detached houses. The appliance has entered the market in 2014. The manufacturer is Austrian Ökofen, which is globally one of the leading manufacturers of pellet boilers. It uses a stirling engine by Microgen to generate electricity. Pilot projects have reached high degree of self-sufficiency in electricity use (70-80 % of generated electricity is used in the building).

The Pellematic micro CHP unit is a boiler room for homes in a compact package. The whole unit needs only 1.5 m² of space and consists of a pellet boiler, a buffer storage tank with 600 l of hot water, the devices for both heating of spaces and domestic hot water, a stirling engine for electricity generation and an automatic pellet feeder. In addition, the system needs a storage for pellets.

The manufacturer can also supply a model which is operated merely as a pellet boiler, generating only heating energy. A stirling engine can be added later in order to co-generate electricity from the same process.

ARKKITEHTUURITOIMISTO
KIMMO LYLYKANGAS OY

OULU

Rakennusvalvonta

customer address
postal address
tel. (customer service)
e-mail
www

Solistinkatu 2, 90140 Oulu
PL 38, 90015 Oulun kaupunki
08 558 42717, 08 558 42718
rakennusvalvonta@ouka.fi
www.ouka.fi/rakennusvalvonta